

MODEL 13250 24 CUBIC FOOT CAPACITY BEAR-PROOF FOOD STORAGE LOCKER



#13250 IGBC
Certification
Number 3766

This 24 cubic foot unit has enough room to fit 2 large coolers and room to spare for plenty of dry goods. Cooler lids can be opened and accessed while still inside the unit. Large easy to operate doors open wide for easy access and can be shut by just swinging them closed.

Optional padlock hasp provides even further security.

MECHANICAL SPECIFICATIONS

- Door hinges are heavy duty stainless steel for superior corrosion resistance and longevity.
- Bear-proof 2 point self latching system with an inner, easy to operate child safety latch release mechanism.
- Unit is fully framed using 1-1/2" x .120" thick wall square tubing with upper and lower panel center supports. Doors are fully framed using 1.0" x .060" thick wall square tubing. Also with middle center supports.
- Housing and door skins are welded 12-gauge steel.
- 1/4" thick mounting plates for 1/2" anchor bolts. (See dimensions shown below)
- Powder coated for superior corrosion protection. Available in Forest Green, Blue, Brown, and Gray.

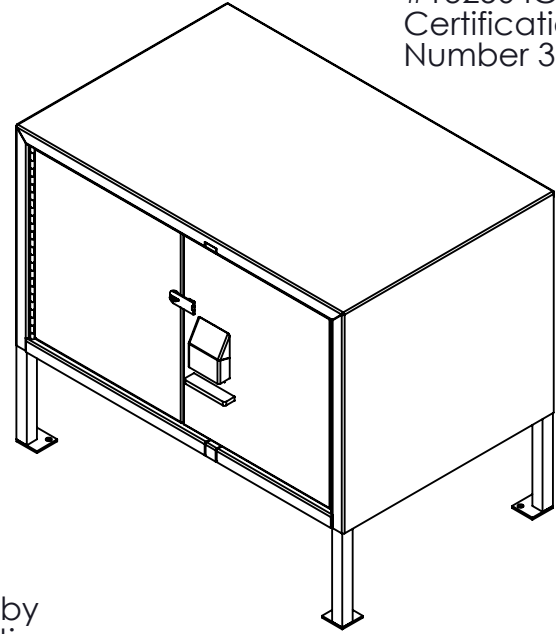

EST. Weight =
360 Lbs

This unit is ADA compliant and has been tested and certified by the USDA Forest Service - MTDC and given a 4 out of 5 star rating for its durability and user friendly design.

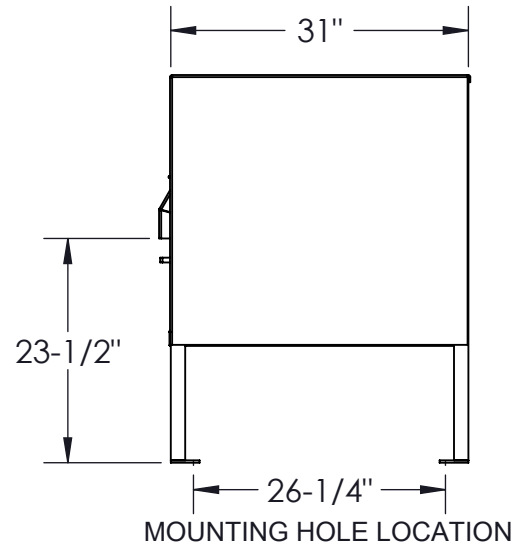
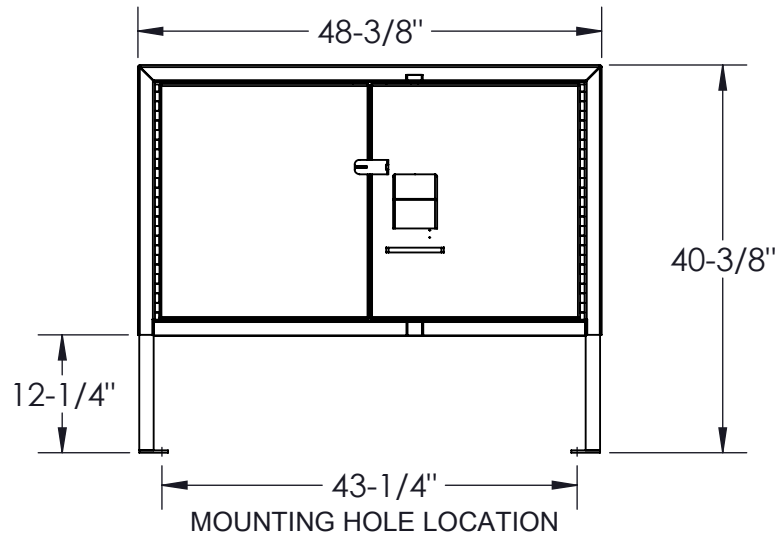

WARNING: MUST BE PERMANENTLY MOUNTED

CUSTOMER APPROVAL :

DATE :



THIS DRAWING, WHICH CONTAINS PROPRIETARY INFORMATION, IS THE PROPERTY OF JAMESTOWN ADVANCED PRODUCTS CORPORATION. IT SHALL NOT BE REPRODUCED IN ANY MANNER NOR DISCLOSED TO THIRD PARTIES WITHOUT WRITTEN PERMISSION OF JAMESTOWN ADVANCED PRODUCTS CORPORATION.

DATE : 3 JAN 08

PRODUCT PART NUMBER : 13250

REV. NO. 3 9/6/16

PRODUCT DESCRIPTION :

24 CUBIC FOOT BEAR-PROOF FOOD LOCKER

2855 GIRTS ROAD
JAMESTOWN, NY 14701