

MODEL 16804-001
30 CUBIC FOOT CAPACITY
BEAR-PROOF FOOD STORAGE LOCKER

This 30 cubic foot unit has enough room to fit 2 large coolers and room to spare for plenty of dry goods. Cooler lids can be opened and accessed while still inside the unit. Large easy to operate doors open wide for easy access and can be shut by just swinging them closed.

Optional padlock hasp provides even further security.



#16804-001 IGBC
 CERTIFICATION
 NUMBER 5216

MECHANICAL SPECIFICATIONS

- Door hinges are heavy duty stainless steel for superior corrosion resistance and longevity.
- Bear-proof 2 point self latching system with an inner, easy to operate child safety latch release mechanism.
- Unit is made fully with welded 14-gauge steel, reinforced bottom, top, & doors add to the unit's longevity.
- 1/4" thick mounting plates for 1/2" anchor bolts. (not included) (See dimensions shown below)
- Powder coated for superior corrosion protection. Available in Forest Green, Blue, Brown, and Gray.
- Approx. weight: 270 lbs.

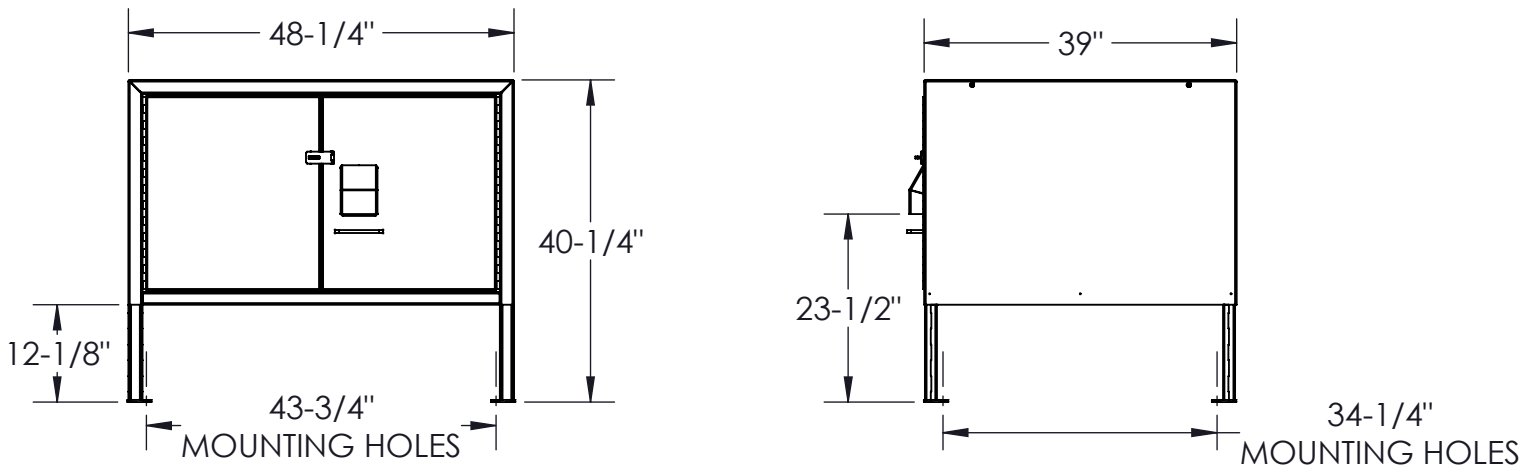
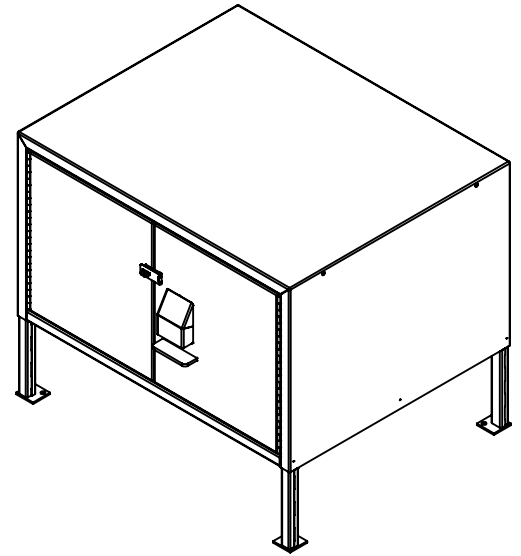

WARNING: MUST BE PERMANENTLY MOUNTED

CUSTOMER APPROVAL :

DATE :



THIS DRAWING, WHICH CONTAINS PROPRIETARY INFORMATION, IS THE PROPERTY OF JAMESTOWN ADVANCED PRODUCTS CORPORATION. IT SHALL NOT BE REPRODUCED IN ANY MANNER NOR DISCLOSED TO THIRD PARTIES WITHOUT WRITTEN PERMISSION OF JAMESTOWN ADVANCED PRODUCTS CORPORATION.

DATE : 12/21/17

PRODUCT PART NUMBER : 16804-001

REV. NO.

PRODUCT DESCRIPTION :

30 CU FT BEAR-PROOF FOOD LOCKER W/O TUBE

2855 GIRTS ROAD
 JAMESTOWN, NY 14701