

# LAKWOOD BIKE RACK

## MODEL #13146-X-X

- 2 bike dual sided rack capable of parking 1 bike per side.
- The centerpost is fabricated using 2-1/2" square x 0.120" wall steel tube. Side tubes are 2" schedule 40 pipe. Decorative top cap is 18 ga. steel. Surface mounting plate is 1/4" thick steel and in-ground anchor is 1" x 6-1/2" 12 ga. steel.
- All welded component fabrication. Approximate weight for surface mount = 32lbs, in-ground mount = 35lbs.
- Mounting options available are surface or in-ground mount.
- There are (3) different finishes available to protect this bike rack from the elements:
  - Powder coated paint finish with your choice of colors (available upon request).
  - Plascoat (thermoplastic powder) is excellent protection against the elements with your choice of colors (available upon request). Plascoat is resistant to stress cracking, adverse weather conditions, detergents, salt spray and typical airborne pollutants. The material maintains excellent adhesion to the metal substrate and provides good abrasion and impact resistance.
  - Hot dip galvanized finish.

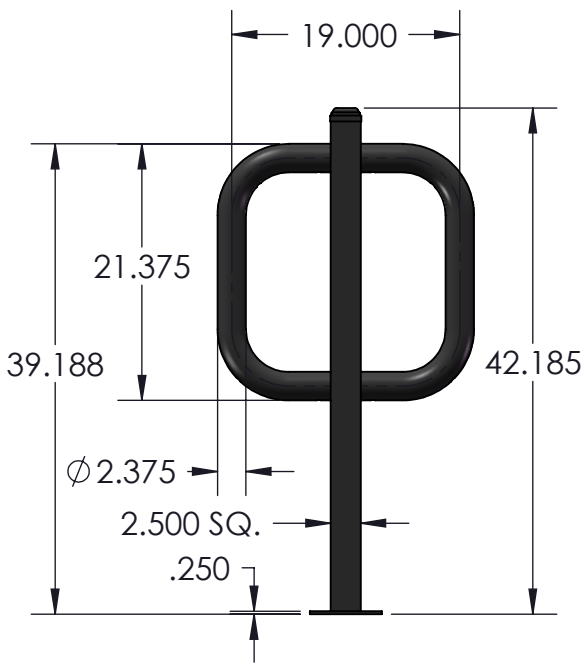

**Surface Mount**  
13146-X-1

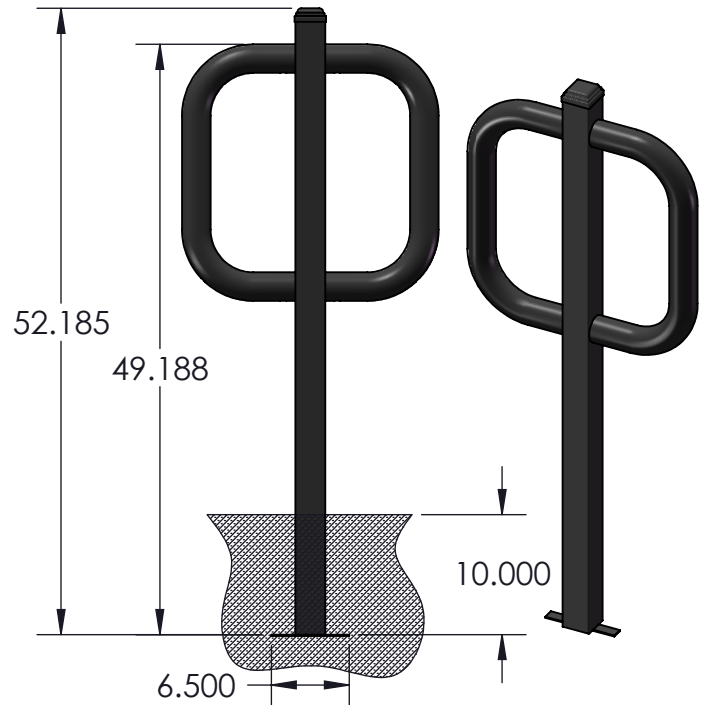

**In-Ground Mount**  
13146-X-2

Part Number	Description
13146-1-1	Powder Coated Surface Mount
13146-1-2	Powder Coated In-Ground Mount
13146-2-1	Plascoat Surface Mount
13146-2-2	Plascoat In-Ground Mount
13146-3-1	Hot Dip Galvanized Surface Mount
13146-3-2	Hot Dip Galvanized In-Ground Mount

**WARNING: MUST BE PERMANENTLY MOUNTED**

CUSTOMER APPROVAL :

DATE :

**JAMESTOWN**  
ADVANCED  
PRODUCTS  
CORPORATION

THIS DRAWING, WHICH CONTAINS PROPRIETARY INFORMATION, IS THE PROPERTY OF JAMESTOWN ADVANCED PRODUCTS CORPORATION. IT SHALL NOT BE REPRODUCED IN ANY MANNER NOR DISCLOSED TO THIRD PARTIES WITHOUT WRITTEN PERMISSION OF JAMESTOWN ADVANCED PRODUCTS CORPORATION.

DATE : 14 NOV 07

PRODUCT PART NUMBER : 13146

REV. NO. 2 12/10/15

PRODUCT DESCRIPTION :

LAKWOOD BIKE RACK

2855 GIRTS ROAD  
JAMESTOWN, NY 14701

PHONE 800-452-0639 -- FAX 716-483-5398 -- WWW.JAMESTOWNADVANCED.COM