

MAYVILLE BIKE RACK
MODEL # 13202-X-XBK

- Multi bike rack capable of parking 4 to 8 bikes.
- The frame is fabricated using (2) 2-1/2" square 0.120 wall steel tubes, multiple stall tubes constructed of 2" schedule 40 pipe, multiple 7 ga. steel gussets, (4) 2-1/2" square tube plastic plugs and (4) 7 ga. steel surface mounting plates.
- All welded component fabrication, approximate weight 4BK = 72 lbs, 6BK = 116lbs and 8BK = 160lbs.
- This bike rack is designed to be surface mount only.
- There are (3) different finishes available to protect this bike rack from the elements:
 - Powder coated paint finish with your choice of colors (available upon request).
 - Thermoplastic coating is excellent protection against the elements with your choice of colors (available upon request). Thermoplastic coating is resistant to stress cracking, adverse weather conditions, detergents, salt spray and typical airborne pollutants. The material maintains excellent adhesion to the metal substrate and provides good abrasion and impact resistance.
 - Hot dip galvanized finish.

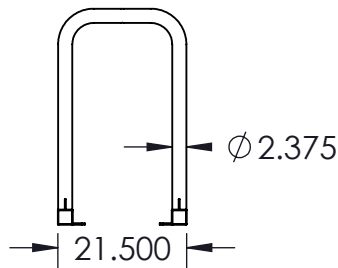
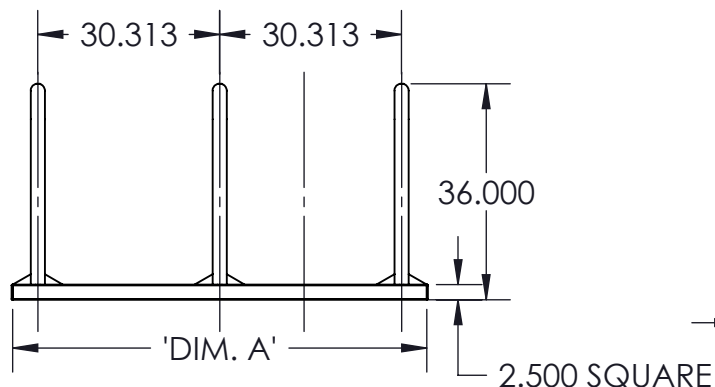
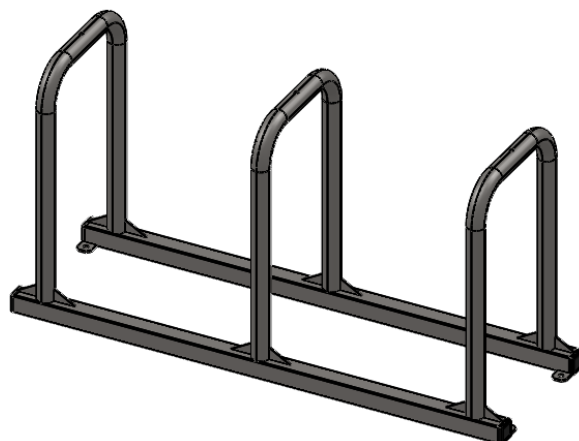
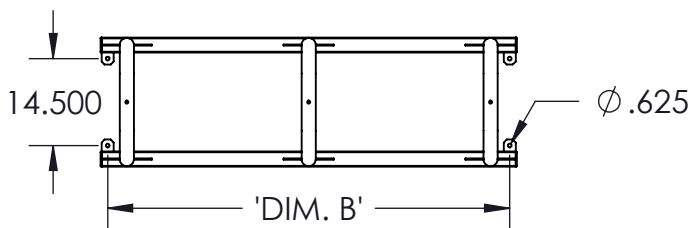

Part Number	Description	DIM. A	DIM. B
13202-1-4BK	4 Bike Rack, Powder Coated Finish	38.688	36.688
13202-2-4BK	4 Bike Rack, Thermoplastic Coating	38.688	36.688
13202-3-4BK	4 Bike Rack, Hot Dip Galvanized	38.688	36.688
13202-1-6BK	6 Bike Rack, Powder Coated Finish	69.000	67.000
13202-2-6BK	6 Bike Rack, Thermoplastic Coating	69.000	67.000
13202-3-6BK	6 Bike Rack, Hot Dip Galvanized	69.000	67.000
13202-1-8BK	8 Bike Rack, Powder Coated Finish	99.313	97.313
13202-2-8BK	8 Bike Rack, Thermoplastic Coating	99.313	97.313
13202-3-8BK	8 Bike Rack, Hot Dip Galvanized	99.313	97.313

WARNING: MUST BE PERMANENTLY MOUNTED

CUSTOMER APPROVAL :

DATE :

JAMESTOWN
ADVANCED
PRODUCTS
 CORPORATION

THIS DRAWING, WHICH CONTAINS PROPRIETARY INFORMATION, IS THE PROPERTY OF JAMESTOWN ADVANCED PRODUCTS CORPORATION. IT SHALL NOT BE REPRODUCED IN ANY MANNER NOR DISCLOSED TO THIRD PARTIES WITHOUT WRITTEN PERMISSION OF JAMESTOWN ADVANCED PRODUCTS CORPORATION.

DATE : 04 AUG 14

PRODUCT PART NUMBER : 13202

REV. NO. 2 12/10/15

PRODUCT DESCRIPTION :

2855 GIRTS ROAD
 JAMESTOWN, NY 14701