

**FALCONER BIKE RACK
MODEL #13212-2-XBK**

- Multi bike rack capable of parking 6 to 26 bikes.
- The frame is fabricated using (4) 2-1/2" square x 0.120 wall steel tubes, (2) 1-1/2" x 2" x 0.120 wall rectangular tubes, (2) 2-1/2" x 3/8" thick flat bars and multiple 1" schedule 40 pipes.
- All welded component fabrication. Approximate weight = 135lbs.
- This bike rack is surface mount only with a plascoat finish:
 - Plascoat (thermoplastic powder) is excellent protection against the elements with your choice of colors (available upon request). Plascoat is resistant to stress cracking, adverse weather conditions, detergents, salt spray and typical airborne pollutants. The material maintains excellent adhesion to the metal substrate and provides good abrasion and impact resistance.

**FALCONER BIKE RACK
MODEL #13212-2-6BK SHOWN**

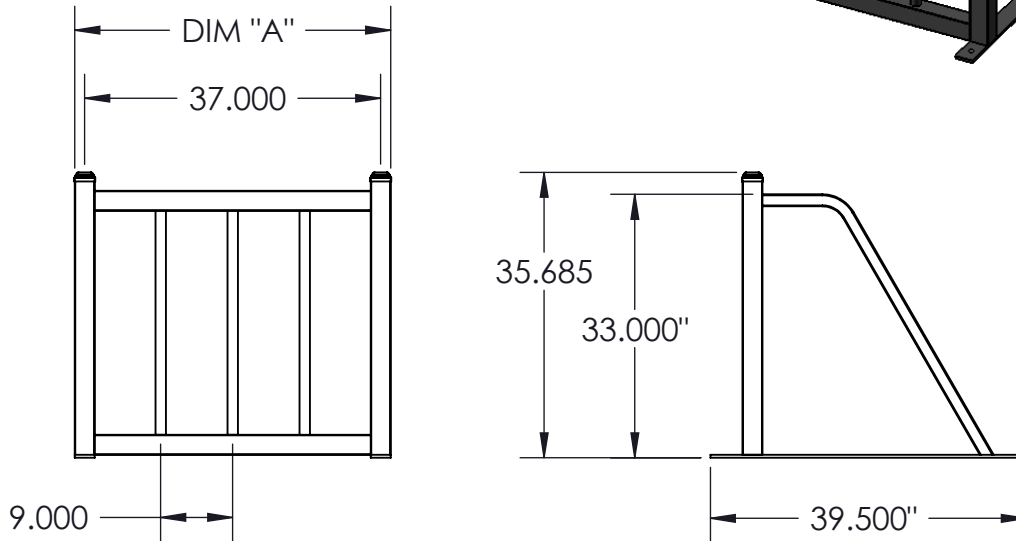
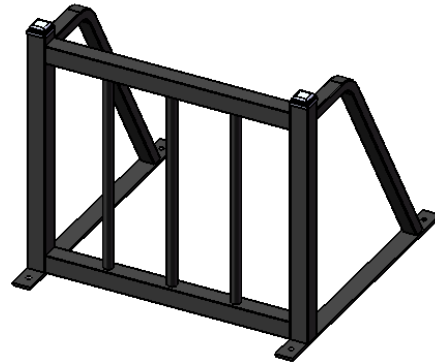

PART NUMBER	DESCRIPTION	DIM "A"	APPROX. WEIGHT
13212-2-6BK	6 Bike Rack, Plascoat finish	39.500"	97lbs
13212-2-10BK	10 Bike Rack, Plascoat finish	75.500"	135lbs
13212-2-14BK	14 Bike Rack, Plascoat finish	111.500"	174lbs
13212-2-18BK	18 Bike Rack, Plascoat finish	147.500"	212lbs
13212-2-22BK	22 Bike Rack, Plascoat finish	183.500"	249lbs
13212-2-26BK	26 Bike Rack, Plascoat finish	219.500"	287lbs

WARNING: MUST BE PERMANENTLY MOUNTED

CUSTOMER APPROVAL :

DATE :



THIS DRAWING, WHICH CONTAINS PROPRIETARY INFORMATION, IS THE PROPERTY OF JAMESTOWN ADVANCED PRODUCTS CORPORATION. IT SHALL NOT BE REPRODUCED IN ANY MANNER NOR DISCLOSED TO THIRD PARTIES WITHOUT WRITTEN PERMISSION OF JAMESTOWN ADVANCED PRODUCTS CORPORATION.

DATE : 5/30/12

PRODUCT PART NUMBER : 13212

REV. NO. 2 12/10/15

PRODUCT DESCRIPTION :

FALCONER BIKE RACK

2855 GIRTS ROAD
JAMESTOWN, NY 14701