

CASSADAGA BIKE RACK MODEL #14670-XXBK

- The end frames are fabricated using 2 3/8" OD X 3/16" thick wall steel tube.
- The vertical stall bars are 5/8" OD solid steel rod.
- All welded component fabrication.
- The end frames and vertical stall structure bolt together so the bike rack may ship flat to reduce shipping and handling costs.
- The vertical stalls hold the front or back tire securely.
- Maximum tire width acceptable is 3".
- Powder coat or thermoplastic is the standard finish. (various colors)

Part #	Bike Capacity	Approx. weight
14670-6BK	6 bikes	75 lbs
14670-10BK	10 bikes	100 lbs
14670-20BK	20 bikes	170 lbs

14670-20BK shown

Middle upright only applies to bike racks over 10 bikes long.

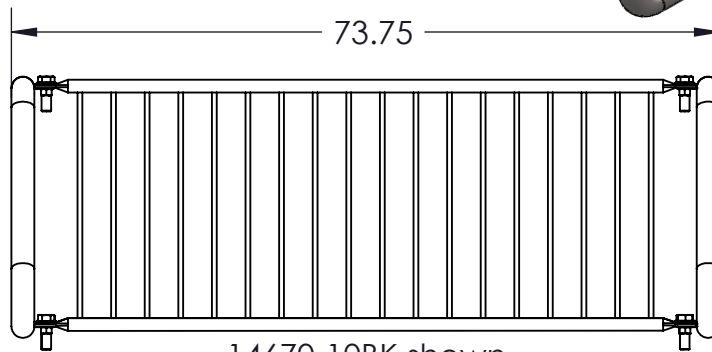
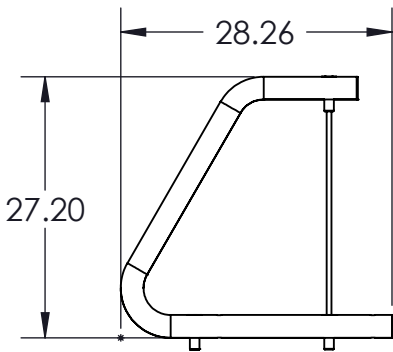

WARNING: MUST BE PERMANENTLY MOUNTED

CUSTOMER APPROVAL :

DATE :

JAMESTOWN
ADVANCED
PRODUCTS
CORPORATION

THIS DRAWING, WHICH CONTAINS PROPRIETARY INFORMATION, IS THE PROPERTY OF JAMESTOWN ADVANCED PRODUCTS CORPORATION. IT SHALL NOT BE REPRODUCED IN ANY MANNER NOR DISCLOSED TO THIRD PARTIES WITHOUT WRITTEN PERMISSION OF JAMESTOWN ADVANCED PRODUCTS CORPORATION.

DATE : 8/30/12

PRODUCT PART NUMBER : 14670

REV. NO. 2 12/10/15

PRODUCT DESCRIPTION :

CASSADAGA BIKE RACK

2855 GIRTS ROAD
JAMESTOWN, NY 14701

PHONE 800-452-0639 -- FAX 716-483-5398 -- WWW.JAMESTOWNADVANCED.COM