

PART NO.	DESCRIPTION
11245	WHEELCHAIR ACCESSIBLE DOUBLE WALLED ADJ. FIRE RING, PAINTED
11245-1	WHEELCHAIR ACCESSIBLE DOUBLE WALLED ADJ. FIRE RING, UNPAINTED
11245-2	WHEELCHAIR ACCESSIBLE DOUBLE WALLED ADJ. FIRE RING, W/S.A. PAINTED
11245-3	WHEELCHAIR ACCESSIBLE DOUBLE WALLED ADJ. FIRE RING, W/S.A. UNPAINTED

- Double wall fire ring has an overall diameter of 35 7/8" x 15 3/4" high complete with drain/draft holes, and is constructed of 3/16" thick steel (A1011).
- Grate is constructed from 1/2" dia. A36 steel bars located on 1 1/8" centers. The four position theft proof grate adjusts from 18 1/4" to 23 3/4" above the firebed, and has a cooking area of 300 sq. inches.
- Grate handles are constructed of a 5/8" dia. A36 steel bar with stay cool spring grips suitable for public use.
- Ring is mounted using staples that allow the ring to tilt back for ease of cleaning or optional spade anchors. The spade anchors permanently anchor the fire ring to the ground.
- All joints are continuously welded.
- All exposed corners are chamfered for safety.
- Standard finish is a non-toxic black powder coat.
- Approximate weight = 232 lbs.

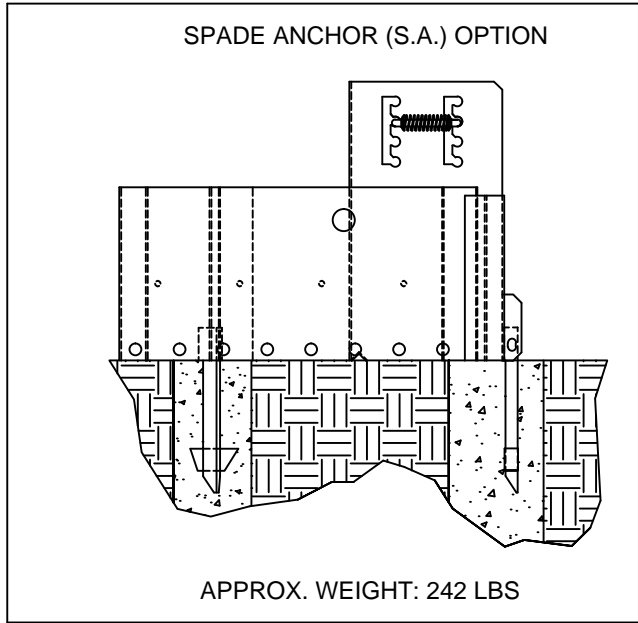
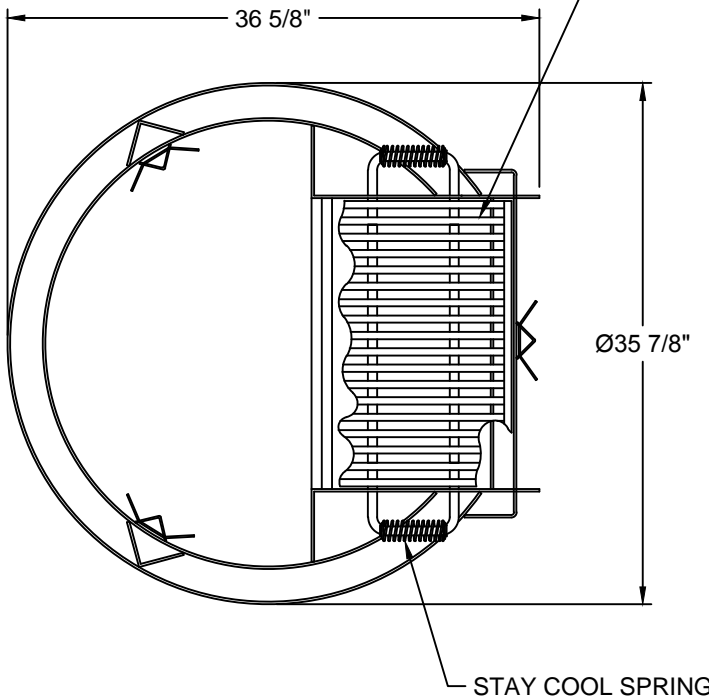
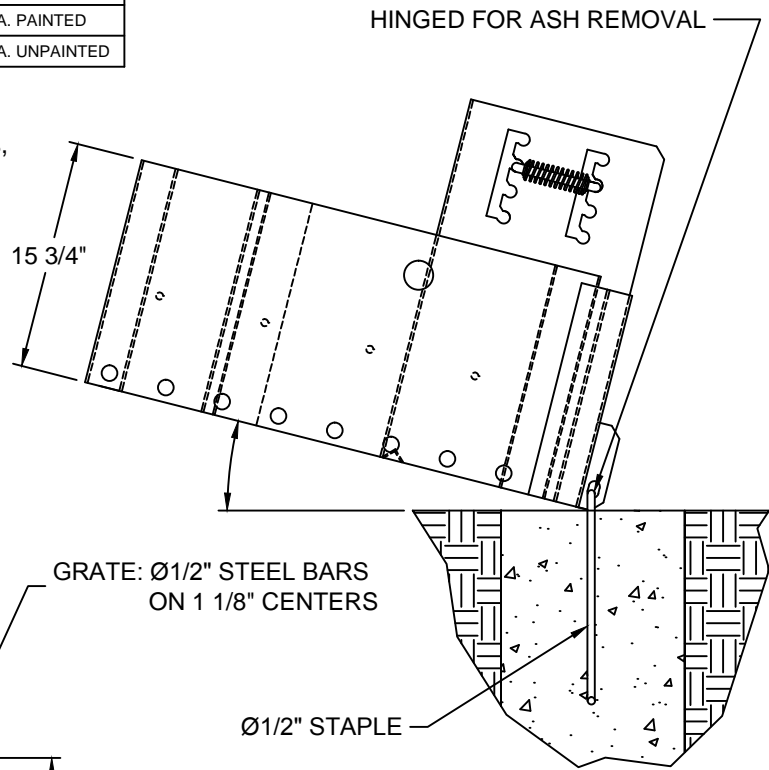

NOTE : CUSTOMER TO PROVIDE CONCRETE ( RECOMMENDED )

APPROX. WEIGHT: 242 LBS

**WARNING: MUST BE PERMANENTLY MOUNTED**

CUSTOMER APPROVAL :

DATE :



THIS DRAWING, WHICH CONTAINS PROPRIETARY INFORMATION, IS THE PROPERTY OF JAMESTOWN ADVANCED PRODUCTS CORPORATION. IT SHALL NOT BE REPRODUCED IN ANY MANNER NOR DISCLOSED TO THIRD PARTIES WITHOUT WRITTEN PERMISSION OF JAMESTOWN ADVANCED PRODUCTS CORPORATION.

DATE : 11-10-01

PRODUCT PART NUMBER : 11245 (THRU -3)

REV. NO. 2 12/9/15

PRODUCT DESCRIPTION :  
WHEELCHAIR ACCESSIBLE, DOUBLE WALLED FIRE RING W/ ADJUSTABLE GRATE

2855 GIRTS ROAD  
JAMESTOWN, NY 14701