

PART NO.	DESCRIPTION
11301	NON-ADJ. FIRE RING, DOUBLE FLANGE, PAINTED
11301-1	NON-ADJ. FIRE RING, DOUBLE FLANGE, UNPAINTED
11301-2	NON-ADJ. FIRE RING, DOUBLE FLANGE, W/O GRATE, PAINTED
11301-3	NON-ADJ. FIRE RING, DOUBLE FLANGE, W/O GRATE, UNPAINTED
11301-4	NON-ADJ. FIRE RING, DOUBLE FLANGE, W/S.A., PAINTED
11301-5	NON-ADJ. FIRE RING, DOUBLE FLANGE, W/S.A., UNPAINTED
11301-6	NON-ADJ. RING, DOUBLE FLANGE, W/O GRATE, W/S.A., PAINTED
11301-7	NON-ADJ. RING, DOUBLE FLANGE, W/O GRATE, W/S.A., UNPAINTED

- Fire ring has an overall diameter of 26 1/8" x 7" high and is constructed of 3/16" thick steel (A569).
- Fire ring is constructed with a formed (not welded) double flange for superior strength.
- Grate is constructed from 1/2" dia. A36 steel bars located on 1 1/8" centers. The non-adjustable theft proof grate has a cooking area of 193 sq. inches.
- Grate handle is constructed of a 5/8" dia. A36 steel bar with stay cool spring grips suitable for public use.
- Ring is mounted using staples that allow the ring to tilt back for ease of cleaning or optional spade anchors. The spade anchors permanently anchor the fire ring to the ground.
- All joints are continuously welded.
- All exposed corners are chamfered for safety.
- Standard finish is a non-toxic black powder coat.
- Approximate weight = 52 lbs.

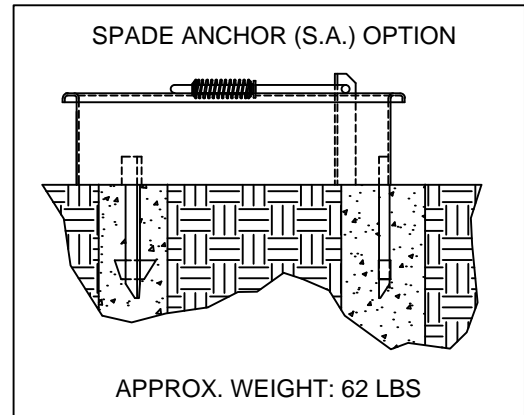
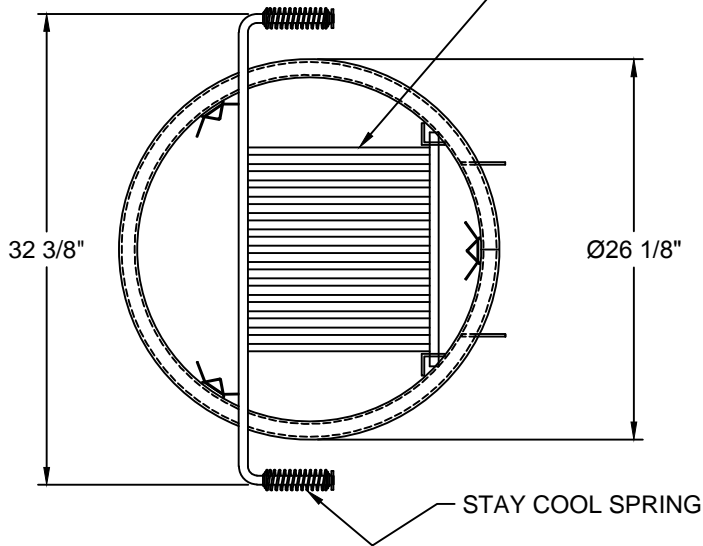
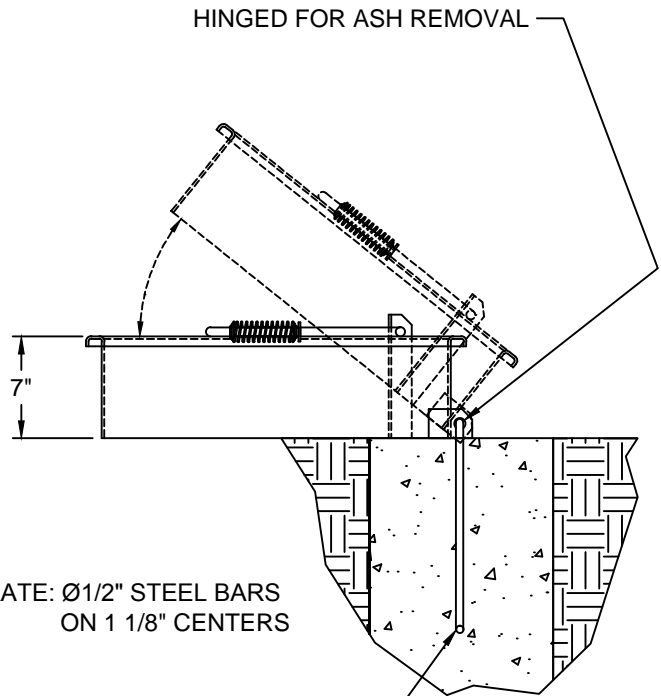

NOTE : CUSTOMER TO PROVIDE CONCRETE ( RECOMMENDED )

## WARNING: MUST BE PERMANENTLY MOUNTED

CUSTOMER APPROVAL :

DATE :

**JAMESTOWN**  
ADVANCED  
PRODUCTS  
CORPORATION

THIS DRAWING, WHICH CONTAINS PROPRIETARY INFORMATION, IS THE PROPERTY OF JAMESTOWN ADVANCED PRODUCTS CORPORATION. IT SHALL NOT BE REPRODUCED IN ANY MANNER NOR DISCLOSED TO THIRD PARTIES WITHOUT WRITTEN PERMISSION OF JAMESTOWN ADVANCED PRODUCTS CORPORATION.

DATE : 11-08-00

PRODUCT PART NUMBER : 11301 (THRU -7)

REV. NO. 1 12/9/15

PRODUCT DESCRIPTION :

Ø24" x 7" HIGH DOUBLE FLANGE FIRE RING  
W/NON-ADJUSTABLE GRATE

2855 GIRTS ROAD  
JAMESTOWN, NY 14701

PHONE 800-452-0639 -- FAX 716-483-5398 -- WWW.JAMESTOWNADVANCED.COM