

PART NO.	DESCRIPTION
11322	WHEELCHAIR ACCESSIBLE DOUBLE WALLED NON-ADJ. RING, PAINTED
11322-1	WHEELCHAIR ACCESSIBLE DOUBLE WALLED NON-ADJ. RING, UNPAINTED
11322-2	WHEELCHAIR ACCESSIBLE DOUBLE WALLED NON-ADJ. RING, FIRE GRATE ONLY, PAINTED
11322-3	WHEELCHAIR ACCESSIBLE DOUBLE WALLED NON-ADJ. RING, FIRE GRATE ONLY, UNPAINTED
11322-4	WHEELCHAIR ACCESSIBLE DOUBLE WALLED NON-ADJ. RING, COOKING GRATE ONLY, PAINTED
11322-5	WHEELCHAIR ACCESSIBLE DOUBLE WALLED NON-ADJ. RING, COOKING GRATE ONLY, UNPAINTED
11322-6	WHEELCHAIR ACCESSIBLE DOUBLE WALLED NON-ADJ. RING, NO GRATES, PAINTED
11322-7	WHEELCHAIR ACCESSIBLE DOUBLE WALLED NON-ADJ. RING, NO GRATES, UNPAINTED

- Double wall fire ring has an overall diameter of 32" x 17" high complete with drain/draft holes, and is constructed of 3/16" thick steel (A1011).
- This fire ring has two grates that are non adjustable and theft proof:
  - Cooking grate is constructed from 1/2" dia. A36 steel bars located on 1 1/8" centers, and has a cooking area of 270 sq. inches.
  - Log grate is constructed from 5/8" dia. A36 steel bars located on 2" centers.
- Grate handle is constructed of a 5/8" dia. A36 steel bar with stay cool spring grips suitable for public use.
- Ring is mounted using staples that allow the ring to tilt back for ease of cleaning.
- All joints are continuously welded.
- All exposed corners are chamfered for safety.
- Standard finish is a non-toxic black powder coat.
- Approximate weight = 210 lbs.

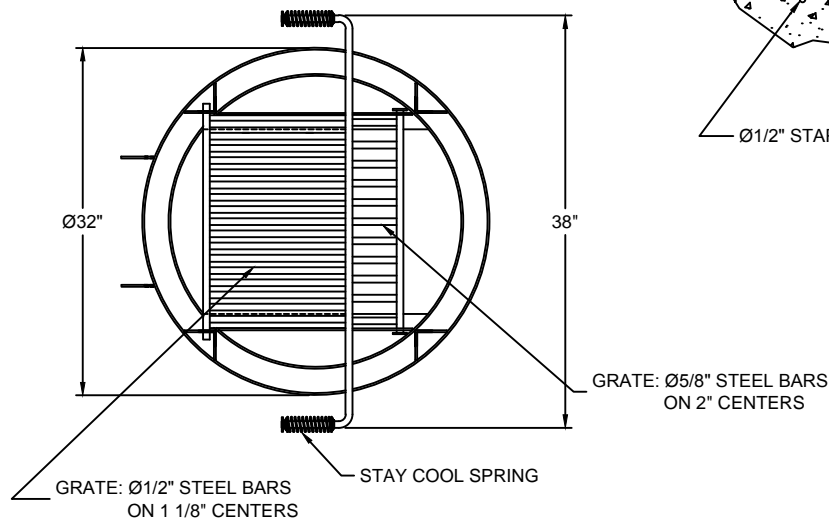
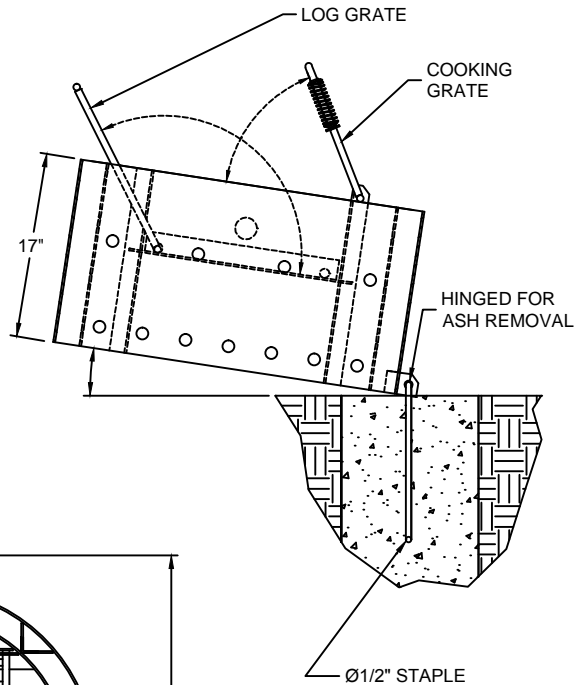

NOTE : CUSTOMER TO PROVIDE CONCRETE ( RECOMMENDED )

**WARNING: MUST BE PERMANENTLY MOUNTED**

CUSTOMER APPROVAL :

DATE :



THIS DRAWING, WHICH CONTAINS PROPRIETARY INFORMATION, IS THE PROPERTY OF JAMESTOWN ADVANCED PRODUCTS CORPORATION. IT SHALL NOT BE REPRODUCED IN ANY MANNER NOR DISCLOSED TO THIRD PARTIES WITHOUT WRITTEN PERMISSION OF JAMESTOWN ADVANCED PRODUCTS CORPORATION.

DATE : 11-15-00

PRODUCT PART NUMBER : 11322 (THRU -7)

REV. NO. 2 12/9/15

PRODUCT DESCRIPTION :  
WHEELCHAIR ACCESSIBLE, DOUBLE WALLED  
FIRE RING W/ NON-ADJUSTABLE GRATE

2855 GIRTS ROAD  
JAMESTOWN, NY 14701