

- Firebox is 20 3/8" lg. x 31 3/4" deep x 10 1/8" high constructed of 3/16" thick steel (A1011) with an integral ash retention flange and drain holes.
- Underside of firebox is reinforced with 4" tapered gussets and 3/16" thick x 1" steel bar rectangular framework.
- Two separate grates are constructed from 1/2" dia. A36 steel bars located on 1 1/8" centers. The four position theft proof grates adjust from 3 1/2" to 9" above the firebed. Each grate has a cooking area of 300 sq. inches for a total of 600 sq. inches.
- Grate handles are constructed from 5/8" dia. A36 steel bars equipped with stay cool spring grips suitable for public use.
- Grill is supported by a heavy duty 4" square gusseted post for stationary concrete mounting. Post mounting plate is 3/16" thick x 10" x 10" and has four holes located on 8 1/2" centers. (Inground mount is also available upon customer request.)
- Standard shelf is 31 3/4" long x 8" deep.
- All joints are continuously welded.
- All exposed corners are chamfered for safety.
- Standard finish is a non-toxic black powder coat.
- Approximate weight = 152 lbs.

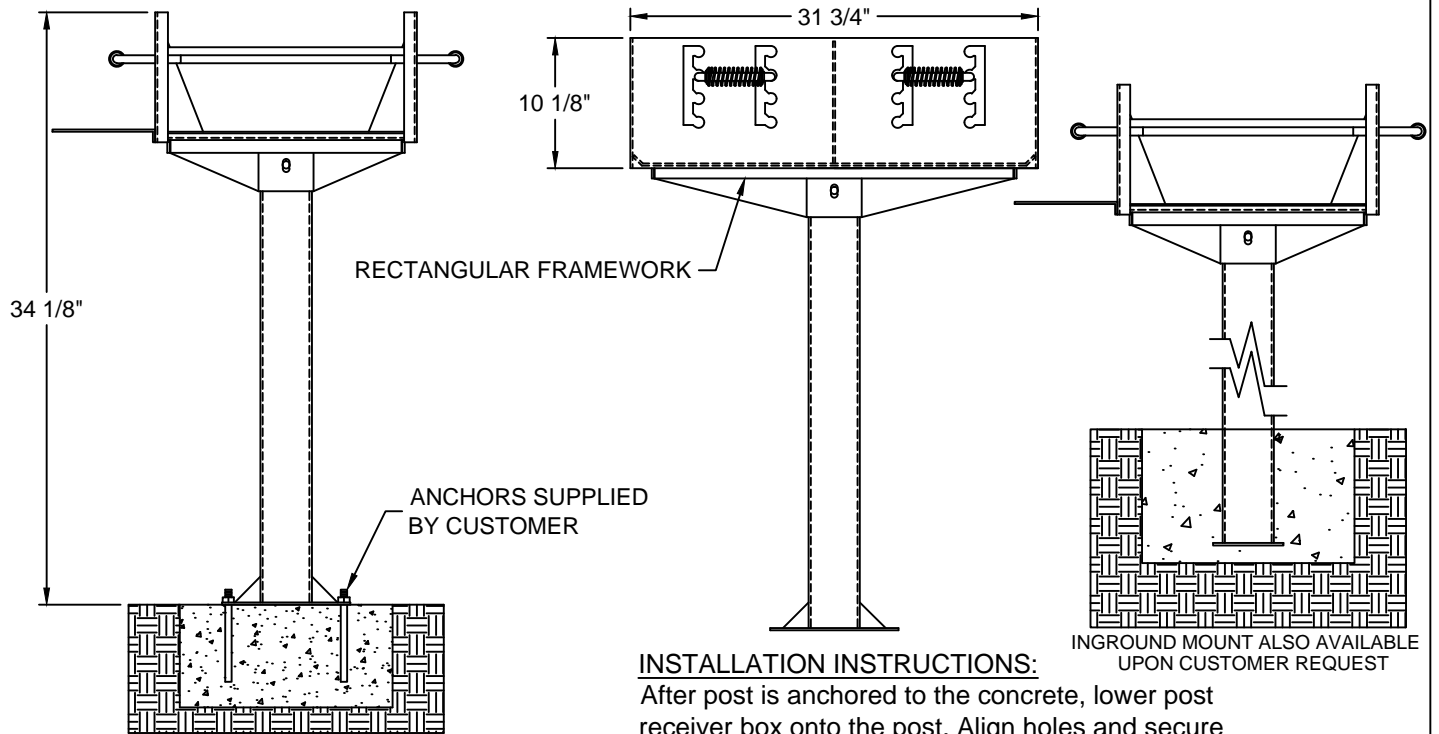

**INSTALLATION INSTRUCTIONS:**

After post is anchored to the concrete, lower post receiver box onto the post. Align holes and secure

NOTE : CUSTOMER TO PROVIDE CONCRETE ( RECOMMENDED ) with the hardware provided.

**WARNING: MUST BE PERMANENTLY MOUNTED**

CUSTOMER APPROVAL :

DATE :



THIS DRAWING, WHICH CONTAINS PROPRIETARY INFORMATION, IS THE PROPERTY OF JAMESTOWN ADVANCED PRODUCTS CORPORATION. IT SHALL NOT BE REPRODUCED IN ANY MANNER NOR DISCLOSED TO THIRD PARTIES WITHOUT WRITTEN PERMISSION OF JAMESTOWN ADVANCED PRODUCTS CORPORATION.

PRODUCT PART NUMBER : 11696

PRODUCT DESCRIPTION :

MEDIUM GROUP GRILL

DATE : 9-10-01

REV. NO. 2 12/10/15

2855 GIRTS ROAD  
JAMESTOWN, NY 14701