

- Firebox is 20 3/8" long x 15" deep x 10 1/8" high constructed of 3/16" thick steel (A1011) with an integral ash retention flange and drain holes.
- Grate is constructed from 1/2" dia. A36 steel bars located on 1 1/8" centers. The four position theft proof grate adjusts from 3 1/2" to 9" above the firebed, and has a cooking area of 300 sq. inches.
- Grate handles are constructed from 5/8" dia. A36 steel bars equipped with stay cool spring grips suitable for public use.
- Grill is supported by a heavy duty 3 1/2" dia. pipe to be installed in concrete. A theft proof base allows the grill to attach to the pipe and to rotate a full 360°.
- Grill design allows grate to lift up and tilt back for ease of cleaning.
- All joints are continuously welded.
- All exposed corners are chamfered for safety.
- Standard finish is a non-toxic black powder coat.
- Approximate weight = 80 lbs.

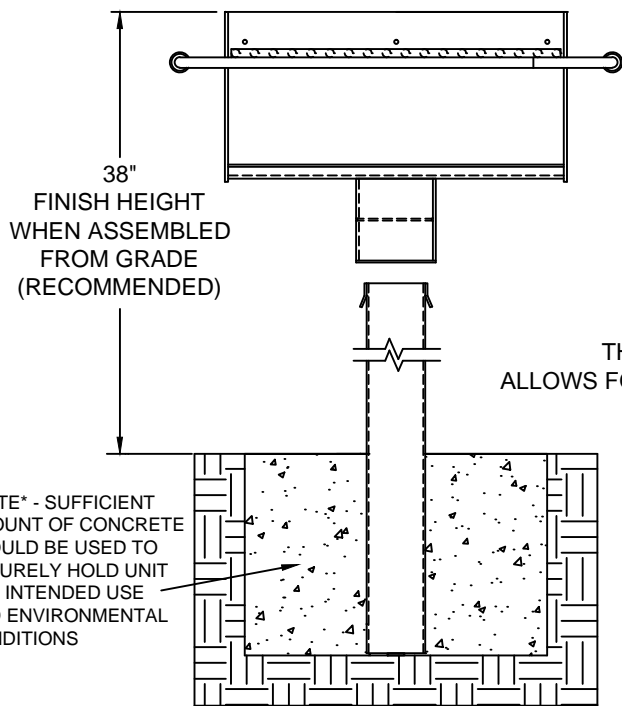

NOTE - SUFFICIENT AMOUNT OF CONCRETE SHOULD BE USED TO SECURELY HOLD UNIT FOR INTENDED USE AND ENVIRONMENTAL CONDITIONS

NOTE : CUSTOMER TO PROVIDE CONCRETE (RECOMMENDED)

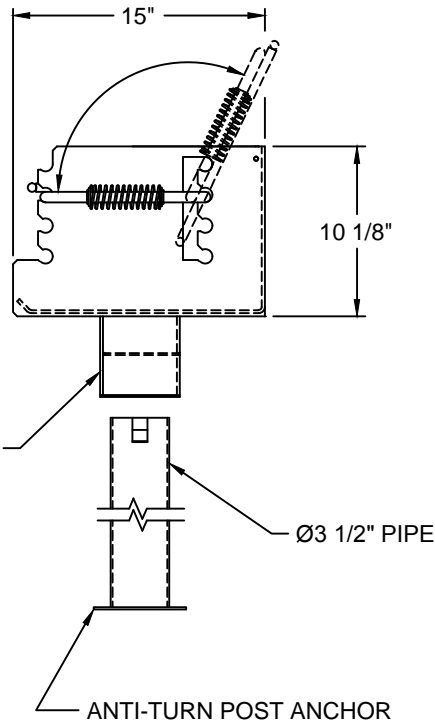

INSTALLATION INSTRUCTIONS:

**After post is installed in concrete, lower lock box onto the tabs. Align tabs, push down over tabs and rotate 90°, push down over tabs again.

WARNING: MUST BE PERMANENTLY MOUNTED

CUSTOMER APPROVAL :

DATE :



THIS DRAWING, WHICH CONTAINS PROPRIETARY INFORMATION, IS THE PROPERTY OF JAMESTOWN ADVANCED PRODUCTS CORPORATION. IT SHALL NOT BE REPRODUCED IN ANY MANNER NOR DISCLOSED TO THIRD PARTIES WITHOUT WRITTEN PERMISSION OF JAMESTOWN ADVANCED PRODUCTS CORPORATION.

DATE : 4-11-01

PRODUCT PART NUMBER : 125-BK

REV. NO. 3 12/9/15

PRODUCT DESCRIPTION :

PARK GRILL WITH TILT BACK GRATE

2855 GIRTS ROAD
JAMESTOWN, NY 14701

PHONE 800-452-0639 -- FAX 716-483-5398 -- WWW.JAMESTOWNADVANCED.COM