

- Table frame design features incorporate a nontip, nontrip & walk-through design.
- A third frame located at the center of the table provides added support (helps prevent sagging) for the plastic lumber.
- The one-piece welded construction frames are fabricated using continuous MIG welds for strength.
- All pipe and tubing conform to ASTM A513-94, and all steel components conform to ASTM-A569.
- All cross braces are 1" schedule 40 pipe (.133" thk. wall).
- Center, table and seat brackets are 1/8" thk. (12 ga.) steel for all recycled plastic tables.
- A diagonal cross brace (1" sch. 40) and end bracket (3/16" thk.) are provided to support the extended portion of the table top. Also, the diagonal cross brace is bent to allow for knee clearance.
- Assembly fasteners are 3/8" dia. galvanized steel carriage bolts.
- Optional plastic lumber is predrilled and has 3/8" radius rounded corners.
- All exposed corners are chamfered for safety.
- Approximate weights of tables less lumber:
 P/N 11575 = 76 lbs
 P/N 11576 = 106lbs
 P/N 11581 = 86 lbs

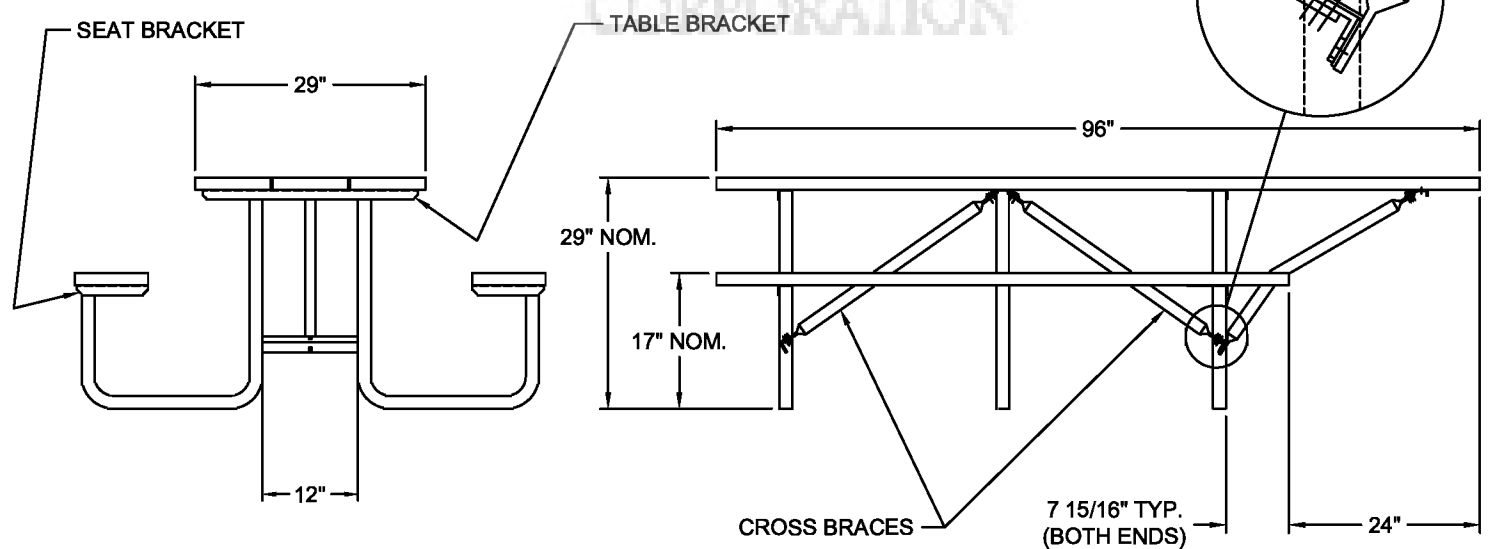

CUSTOMER APPROVAL :

DATE :

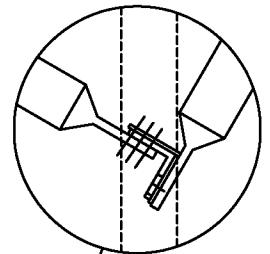

THIS DRAWING, WHICH CONTAINS PROPRIETARY INFORMATION, IS THE PROPERTY OF JAMESTOWN ADVANCED PRODUCTS CORPORATION. IT SHALL NOT BE REPRODUCED IN ANY MANNER NOR DISCLOSED TO THIRD PARTIES WITHOUT WRITTEN PERMISSION OF JAMESTOWN ADVANCED PRODUCTS CORPORATION.

DATE : 4-5-01

PRODUCT PART NUMBER : 11575, 76 & 81 (-9 THRU -12)

REV. NO. 2

PRODUCT DESCRIPTION :
 8' HANDICAPPED PICNIC TABLE
 WITH RECYCLED PLASTIC LUMBER

2855 GIRTS ROAD
 JAMESTOWN, NY 14701