

- Wheelchair accessibility at both ends.
- Seats are the same length as the table top, thus a benefit over the extended top design.
- Meets or exceeds current ADA guidelines for wheelchair access to picnic tables.
- The one-piece welded construction frames are fabricated using continuous MIG welds for strength.
- All pipe and tubing conform to ASTM A513-94, and all steel components conform to ASTM-A569.
- All cross braces are 1" schedule 40 pipe (.133" thk. wall).
- Center brackets are all 1/8" thk. (12 ga.) steel. Table and seat brackets are 1/8" thk. (12 ga.) steel for P/N's 12607, 12608 and 12609, and 3/16" thk. (7 ga.) steel for P/N 12610.
- Support brackets are 1/8" thk.(12 ga.) steel.
- Assembly fasteners are 3/8" dia. galvanized steel carriage bolts.
- Optional lumber is predrilled and has 3/8" radius rounded corners.
- All exposed corners are chamfered for safety.
- Approximate weights of tables less lumber:  
 P/N 12607 = 80 lbs  
 P/N 12608 = 65 lbs  
 P/N 12609 = 55 lbs  
 P/N 12610 = 100 lbs

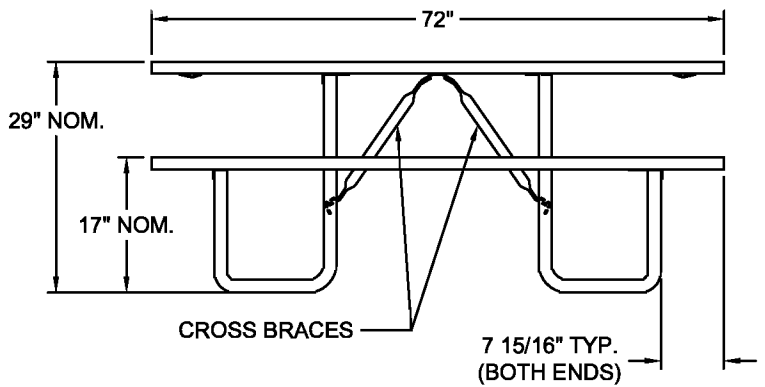
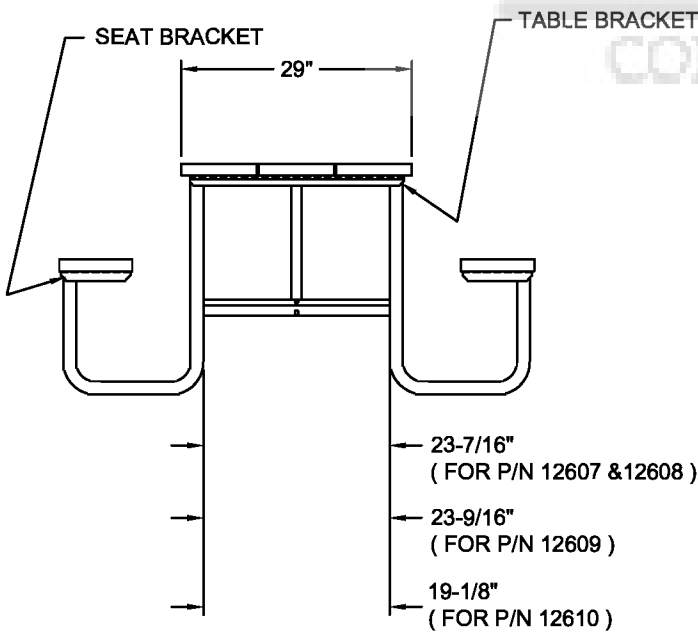
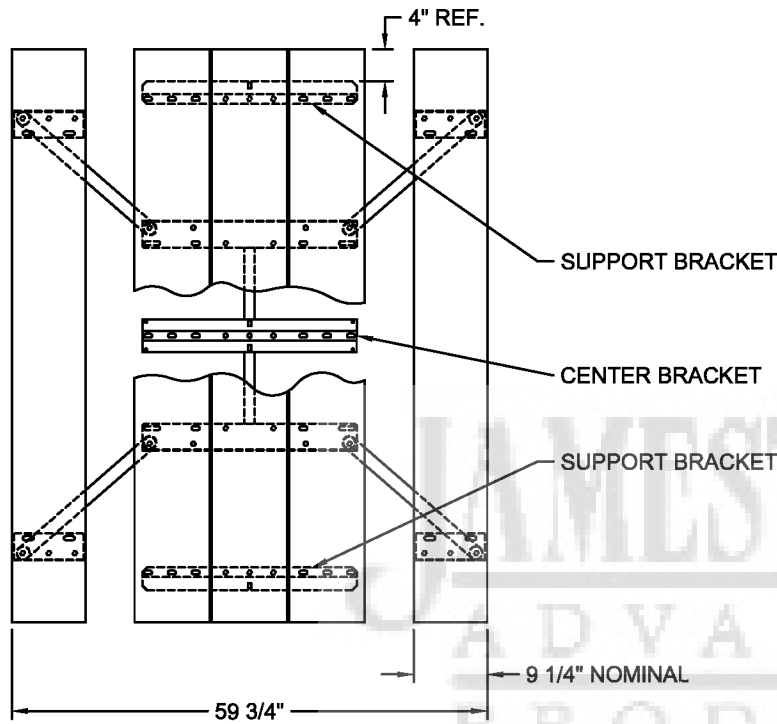

CUSTOMER APPROVAL :

DATE :

**JAMESTOWN**  
 ADVANCED  
 PRODUCTS  
 CORPORATION

THIS DRAWING, WHICH CONTAINS PROPRIETARY INFORMATION, IS THE PROPERTY OF JAMESTOWN ADVANCED PRODUCTS CORPORATION. IT SHALL NOT BE REPRODUCED IN ANY MANNER NOR DISCLOSED TO THIRD PARTIES WITHOUT WRITTEN PERMISSION OF JAMESTOWN ADVANCED PRODUCTS CORPORATION.

DATE : 09-08-06

PRODUCT PART NUMBER : 12607, 08, 09 & 10 (-1 THRU -6)

REV. NO. 1

PRODUCT DESCRIPTION :  
 6' UNIVERSAL ACCESS PICNIC TABLE

2855 GIRTS ROAD  
 JAMESTOWN, NY 14701