

ETL-Certified, NEMA type 3R rainproof enclosure.
 One piece construction from G90 galvanized steel.
 All surfaces have electrostatic gray powder coated finish.
 120/240 volt single phase, 125 Amp.
 Suitable for campground / RV and temporary service.
 Commercial quality receptacles.
 Loop feed lugs on all pedestals up to 350 MCM wire.
 Tin plated copper stabs standard.
 All units factory wired.
 All units standard with hub openings, closure plate included.
 All 9" boxes are 9.125" wide.

Please review the diagrams and sign and date below. All drawings are the property of Jamestown advanced Products. Distribution of drawings without the consent of Jamestown Advanced Products is prohibited

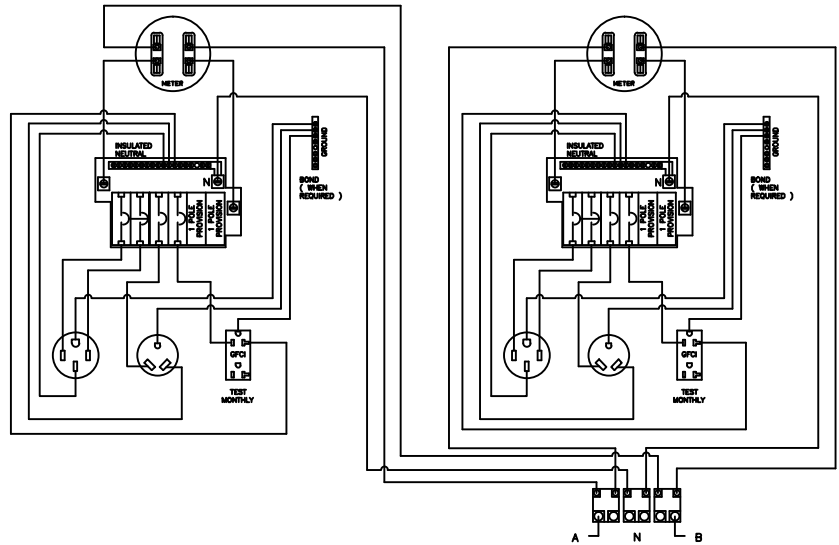

WARNING: MUST BE PERMANENTLY MOUNTED

CUSTOMER APPROVAL :

DATE :

JAMESTOWN
 ADVANCED
 PRODUCTS
 CORPORATION

THIS DRAWING, WHICH CONTAINS PROPRIETARY INFORMATION, IS THE PROPERTY OF JAMESTOWN ADVANCED PRODUCTS CORPORATION. IT SHALL NOT BE REPRODUCED IN ANY MANNER NOR DISCLOSED TO THIRD PARTIES WITHOUT WRITTEN PERMISSION OF JAMESTOWN ADVANCED PRODUCTS CORPORATION.

DATE : 7/20/22

PRODUCT PART NUMBER : 34-RT-123-S3

REV. NO.

PRODUCT DESCRIPTION :
 9" WIDE UTILITY BOX, 50-30-20
 PEDESTAL WITH METER BACK TO BACK (SERIES 3)

2855 GIRTS ROAD
 JAMESTOWN, NY 14701

PHONE 800-452-0639 -- FAX 716-483-5398 -- WWW.JAMESTOWNADVANCED.COM