

MODEL 13595-32
32 GALLON CAPACITY
ANIMAL RESISTANT TRASH/TRASH RECEPTACLE

- Uses one standard 32 gallon recycle type bag.
- ADA compliant.
- Easy access top loading chute.
- Pivoting bag racks for easy trash removal.

Mechanical specifications

- Door hinges are heavy duty stainless steel for superior corrosion resistance and longevity.
 - Animal resistant internal single point self latching system on service hatch.
 - Welded 14 gauge construction.
 - 3/16" thick mounts with (4) holes bored to fit 1/2" bolts.
 - Powder coated for superior corrosion protection.
- Available in forest green, blue, brown, and gray.

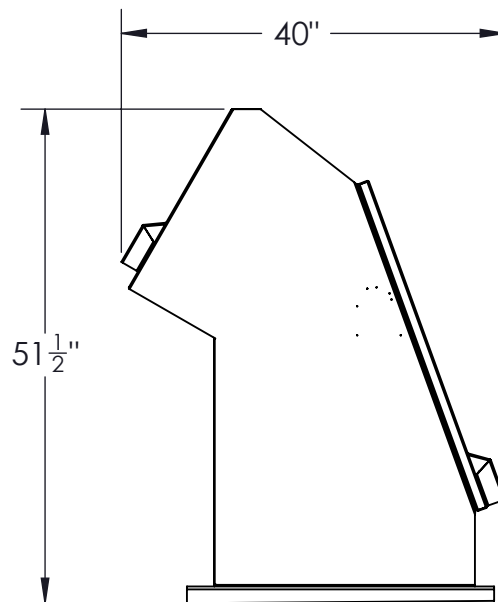
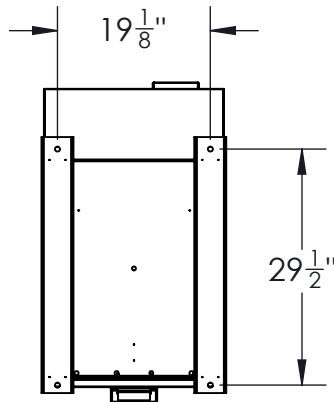
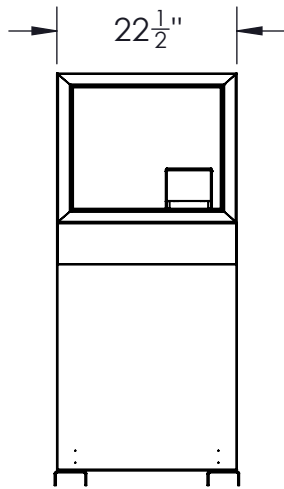

ESTIMATED WEIGHT: 190 LBS

WARNING: MUST BE PERMANENTLY MOUNTED

CUSTOMER APPROVAL :

DATE :

JAMESTOWN
ADVANCED
PRODUCTS
 CORPORATION

THIS DRAWING, WHICH CONTAINS PROPRIETARY INFORMATION, IS THE PROPERTY OF JAMESTOWN ADVANCED PRODUCTS CORPORATION. IT SHALL NOT BE REPRODUCED IN ANY MANNER NOR DISCLOSED TO THIRD PARTIES WITHOUT WRITTEN PERMISSION OF JAMESTOWN ADVANCED PRODUCTS CORPORATION.

DATE : 1-22-13

PRODUCT PART NUMBER : 13595-32

REV. NO. 2 12/10/15

PRODUCT DESCRIPTION :

ANIMAL RESISTANT TRASH RECEPTACLE

2855 GIRTS ROAD
 JAMESTOWN, NY 14701