

MODEL 13595
64 GALLON CAPACITY
ANIMAL RESISTANT TRASH/TRASH RECEPTACLE

- Uses two standard 32 gallon recycle type bags.
- ADA compliant.
- Easy access top loading chutes.
- Pivoting bag racks for easy trash removal.

Mechanical specifications

- Door hinges are heavy duty stainless steel for superior corrosion resistance and longevity.
 - Animal resistant internal single point self latching system on service hatch.
 - Welded 14 gauge construction.
 - 3/16" thick mounts with (4) holes bored to fit 1/2" bolts.
 - Powder coated for superior corrosion protection.
- Available in forest green, blue, brown, and gray.

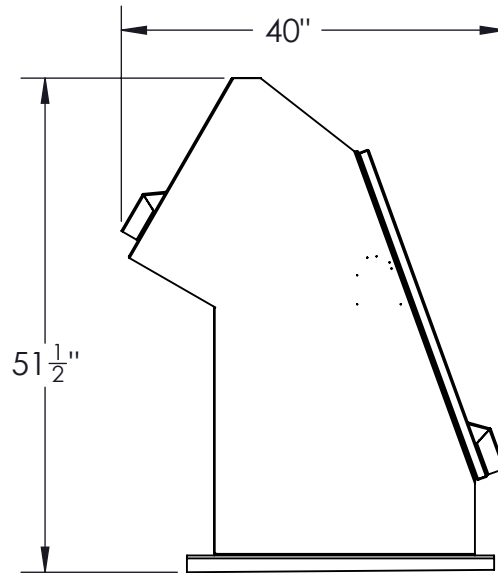
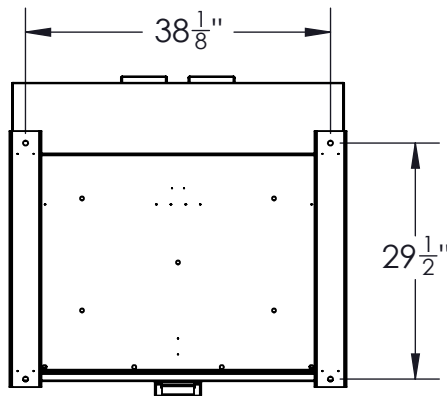
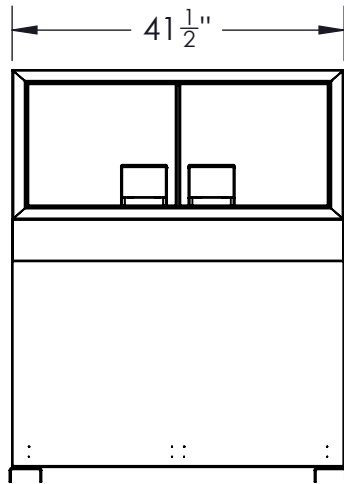

ESTIMATED WEIGHT: 285 LBS

WARNING: MUST BE PERMANENTLY MOUNTED

CUSTOMER APPROVAL :

DATE :

JAMESTOWN
ADVANCED
PRODUCTS
 CORPORATION

THIS DRAWING, WHICH CONTAINS PROPRIETARY INFORMATION, IS THE PROPERTY OF JAMESTOWN ADVANCED PRODUCTS CORPORATION. IT SHALL NOT BE REPRODUCED IN ANY MANNER NOR DISCLOSED TO THIRD PARTIES WITHOUT WRITTEN PERMISSION OF JAMESTOWN ADVANCED PRODUCTS CORPORATION.

DATE : 1-22-13

PRODUCT PART NUMBER : 13595

REV. NO. 2 12/10/15

PRODUCT DESCRIPTION :

ANIMAL RESISTANT TRASH/TRASH RECEPTACLE

2855 GIRTS ROAD
 JAMESTOWN, NY 14701