

MODEL 13596
64-110 GALLON CAPACITY
ANIMAL PROOF RECYCLE/RECYCLE ENCLOSURE

- Capacity is determined by bag sized used.
- ADA compliant.
- Easy access top loading chutes.
- Pivoting bag racks for easy trash removal.

Mechanical Specifications

- Door hinges are heavy duty stainless steel for superior corrosion resistance and longevity.
 - Animal resistant internal single point self latching system on service hatch.
 - Welded 14 gauge construction.
 - 3/16" thick mounts with 4 holes bored to fit 1/2" bolt. (see dimensions shown below).
 - Powder coated for superior corrosion protection.
- Available in Forest Green, Blue, Brown, and Grey.
- Estimated Weight: 290 lbs.

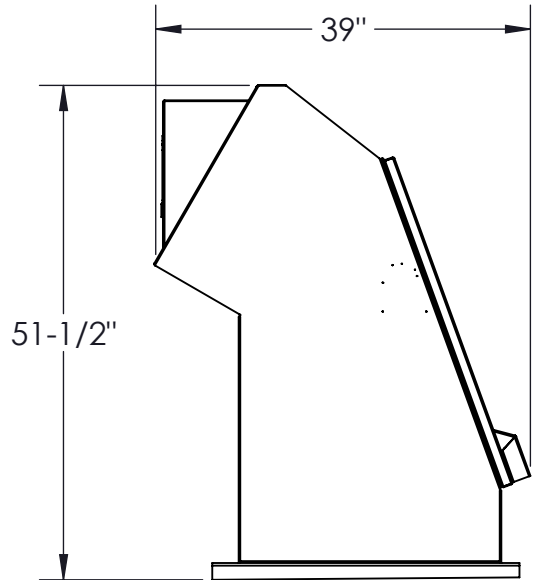
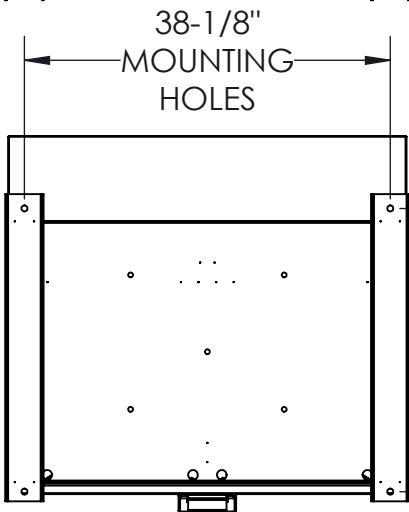
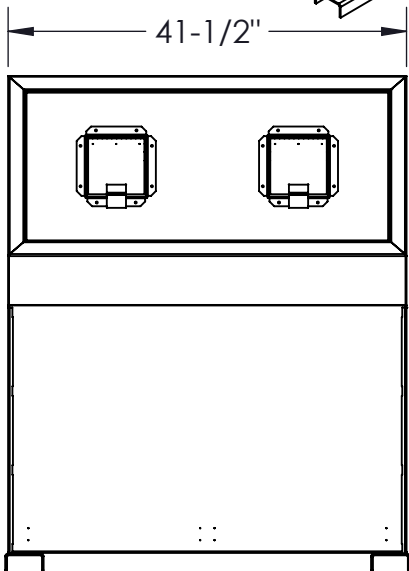

WARNING: MUST BE PERMANENTLY MOUNTED

CUSTOMER APPROVAL :

DATE :

JAMESTOWN
ADVANCED
PRODUCTS
 CORPORATION

THIS DRAWING, WHICH CONTAINS PROPRIETARY INFORMATION, IS THE PROPERTY OF JAMESTOWN ADVANCED PRODUCTS CORPORATION. IT SHALL NOT BE REPRODUCED IN ANY MANNER NOR DISCLOSED TO THIRD PARTIES WITHOUT WRITTEN PERMISSION OF JAMESTOWN ADVANCED PRODUCTS CORPORATION.

DATE : 8/17/17

PRODUCT PART NUMBER : 13596

REV. NO.

PRODUCT DESCRIPTION :

Animal Resistant Recycle/Recycle Bin

2855 GIRTS ROAD
 JAMESTOWN, NY 14701